

Impression Rail™ Express

Open Mid-Rail Installation Guide

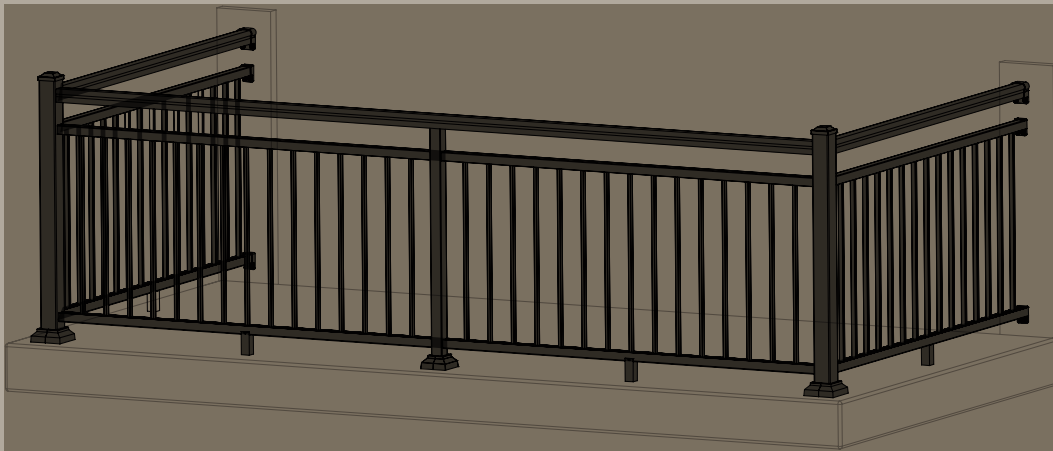

Aluminum Posts	4
Level Panels	8
Stair Panels	11



Important Information

- Please read all instructions completely before starting any part of the installation. Always make sure to visit www.TimberTech.com to ensure you are viewing the most current installation instructions, care and cleaning, technical information and more.
- Impression Rail Express should be installed using the same good building principles used to install wood, composite, or metal railing and in accordance with the local building codes and the installation guidelines included below.
- The AZEK Co. LLC accepts no liability or responsibility for the improper installation of this product.
- Impression Rail Express may not be suitable for every application and it is the sole responsibility of the installer to be sure that Impression Rail is fit for the intended use. Since all installations are unique, it is also the installer's responsibility to determine specific requirements in regards to each rail application.
- The AZEK Co. LLC recommends that all applications be reviewed by a licensed architect, engineer or local building official before installation. If you have any questions or need further assistance, please call AZEK Customer Service at 877-ASK-AZEK (877-275-2935), or visit our website at www.TimberTech.com.
- Impression Rail Express is tested as a whole system and should be used that way. It is not intended to be used in conjunction with other railing systems or fasteners.
- The following Installation Guidelines are applicable for installation of Impression Rail Express only.
- **IMPORTANT:** Make sure the DRIVE TOOL/DRILL is configured or set to use the SCREW setting when driving and/or tightening all FASTENERS.
- **SAFETY:** Always wear goggles when handling, cutting, drilling and fastening materials.
- Failure to install this product in accordance with applicable building codes and Impression Rail Express's written Rail Install Guide may lead to personal injury, affect rail system performance and void the product warranty.
- The buildup or generation of static electricity is a naturally occurring phenomenon in many plastic based products such as carpeting, upholstery, and clothing, and can occur on alternative decking under certain environmental conditions. This static electricity can discharge once contact is made with hardware, railing, or other conductors of electricity.

Standard Open Mid-Rail System

Each Panel Requires:

- 36" X 6' Panel Kit
- One additional Bottom Snap
- One unpunched H-Channel
- Rail Attach Kit (one kit for two panels)
- 6 Deck Rail Clips per bay

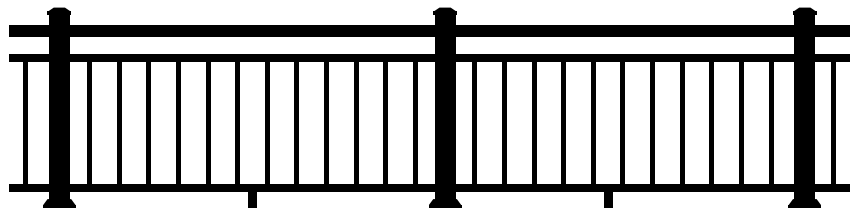

Continuous Top Rail Open Mid-Rail System

Each Panel Requires:

- 36" X 6' or 8' Continuous Top Rail Panel Kits
- One additional Bottom Snap
- One unpunched H-Channel
- Rail Attach Kit (one kit for two panels)
- Continuous Top Rail (span up to 18')
- 5 Deck Rail Clips per bay
- One Crossover Bracket

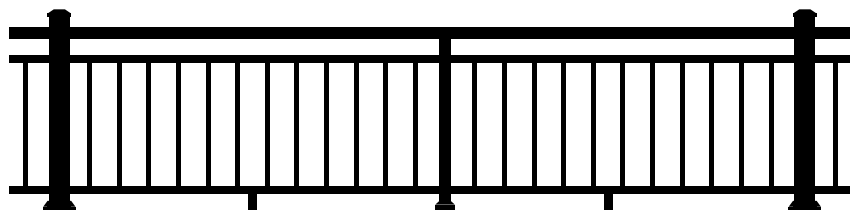

Important Note:

Prior to construction, check with your local regulatory agency for special code requirements in your area.

Common railing height is 36" or 42". Post spans will vary depending on job site conditions. Never span more than 8' on-center between railing posts. Spans longer than 12' in length will require reduced post spans. When you cut a kit to create two panels, for instance, cutting 8' to two 4', you will need an additional hardware kit. Read instructions completely to get an understanding of how the product goes together and how each piece affects the other.

Installing Impression Rail™ Express Open Mid-Rail Aluminum Railing System



CONCRETE APPLICATIONS

WHEN POSTS ARE SECURED TO CONCRETE SUBSTRATES USE CONCRETE ANCHORS (SOLD SEPARATELY)

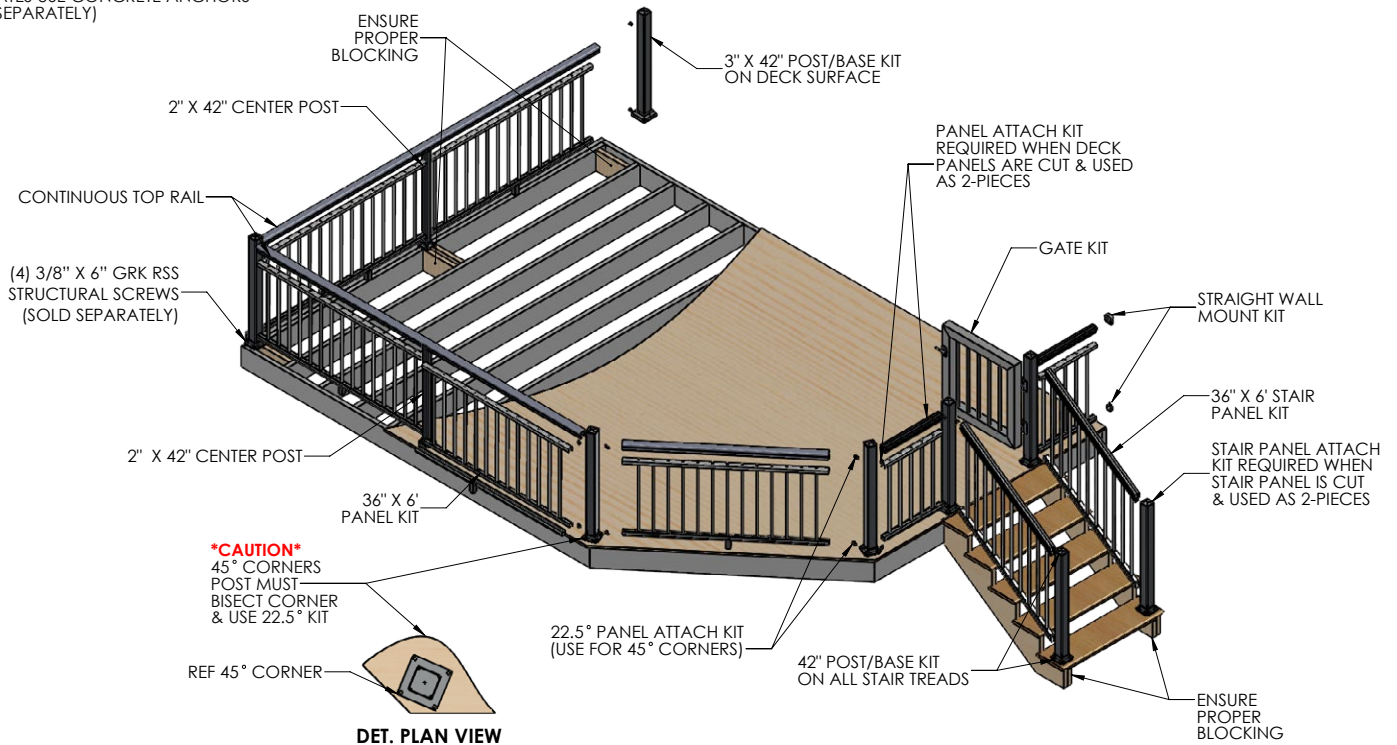

Important Note:

42" posts and 36" high railing panels (34" actual size) are required to build 42" high Open Mid-Rail System on a level surface. 48" posts are required for stair applications.

NOTE: IF INSTALLING POST LIGHTING, WIRING MUST BE INSTALLED PRIOR TO SECURING POSTS TO DECK/STAIR SURFACE AND INSTALLING TOP RAIL SNAPS.

It is the responsibility of the installer to meet all local code requirements and obtain all required building permits. The installer should determine and implement appropriate installation techniques for each installation situation. AZEK Co. LLC or its reseller shall not be held responsible for improper or unsafe installations.

Suggested Tools:

- Appropriate fasteners for mounting posts to deck
- Miter saw with carbide-tipped non-ferrous blade
- Cordless drill
- Tape measure
- Level
- Power cords, drop sheets and safety glasses
- 3/16" Drill bit
- 6" #2 Square drive bit
- Installation jig (optional)



Important Note:

Actual Level Panel Lengths Are As Follows:

- 6' Panels = 69.43"
- 8' Panels = 91.31"
- 3" posts are required to reach 6' & 8' lengths

1 Determine All Posts Needed and Prepare (end, center or corner)

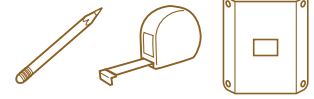

⚠ Important Note:

3" posts are required to reach 6' and 8' lengths. 2" posts must be set in-line to panel. **Do not install post caps and vinyl post base covers until railing assembly is completed.**

Install Lower Deck Rail Clips – Two Options:

Option A - When No Installation Jig Is Available

- Measure 2 7/8" from top of casting shoulder and place a pencil mark for location of the top edge of the rail clip. (Dia. #1)
- Center clip on post and secure with (2) - #8x3/4" self-drilling screws. Clips are included in the Panel Kits.

Option B - Using Installation Jig (Sold separately. Accessory pack includes Installation Jig and Touch-up paint.)

- Place Installation Jig (w/arrow facing base plate) on top of base plate upper edge. (Dia. #2)
- Place clip in hole and fasten with (2) - #8x3/4" self-drilling screws. Clips are included in the Panel Kits.

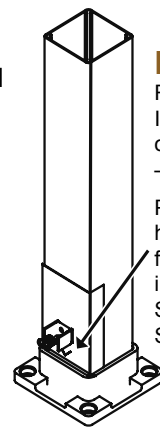

Dia. #2

Rest Installation Jig on Base Plate – Arrow Down

Place Clip in hole, hold clip firmly while installing (2) Self-Drilling Screws.

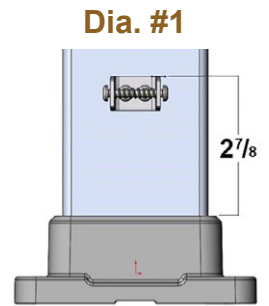

Dia. #1

2 How to Secure 3" Posts to Deck

- Install proper post blocking (Dia. #3A & 3B). Use proper attachment screws or anchors shown in diagram. (Hardware for post attachment are not provided with the posts.)
- With 3/16" drill bit, pre-drill through deck boards and into blocking. (Dia. #3C)
- Drill a 5/8" hole in center of four deck screw holes for lighting wires (optional).
- Level and plumb post using shims.
- Secure posts to deck frame with suggested screws. (Dia. #3B)
- *Verify local code requirements for post attachment hardware.
- Install post caps (after panels are installed). (Dia. #4)

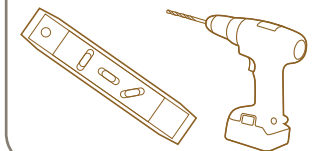

Dia. #3A (TOP VIEW)

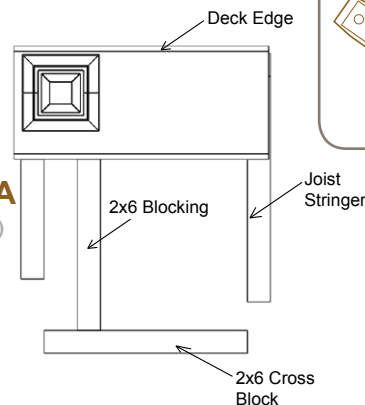

Dia. #3B (SIDE VIEW)

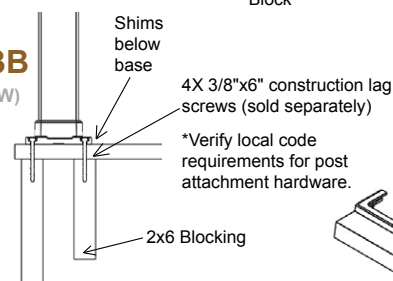

Dia. #3C (TOP VIEW)

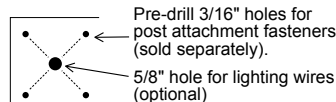

Dia. #4

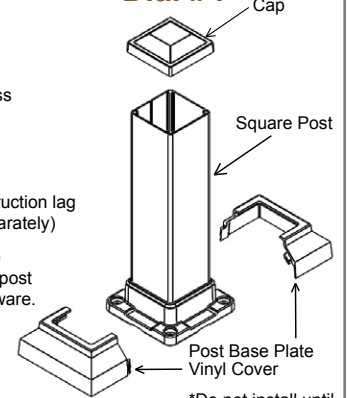

*Do not install until railing assembly is completed.

3 Install Stair End Posts (if applicable)

- Temporarily install end stair post so rail centerline aligns with top stair posts installed in Step 1 (if applicable). Recommended post installation locations are shown. (Dia. #5) Confirm with local code officials before installing stair rail sections or stair rail posts to ensure compliance with local code requirements.

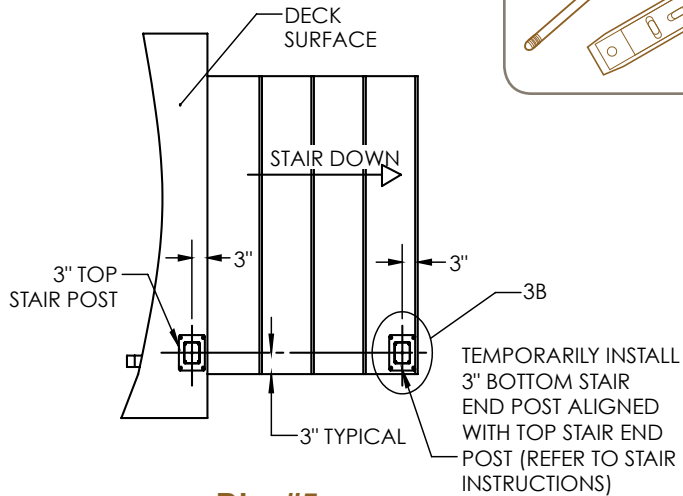

Dia. #5

4 Install End Posts (if applicable)

Install posts at all end locations with maximum gap between post and wall to be less than a 4" opening. (Dia. #6)



Important Note:

3" posts are required at all transitions. 2" posts may not be used to start/end a run or to form a corner.

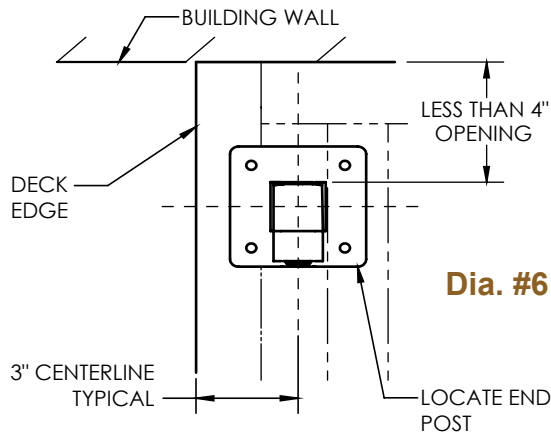

Dia. #6

5 Install 90-degree Corner Posts

Position post on same 3" centerline (typical) and temporarily fasten using a single fastener through base plate mounting hole. (Dia. #7)

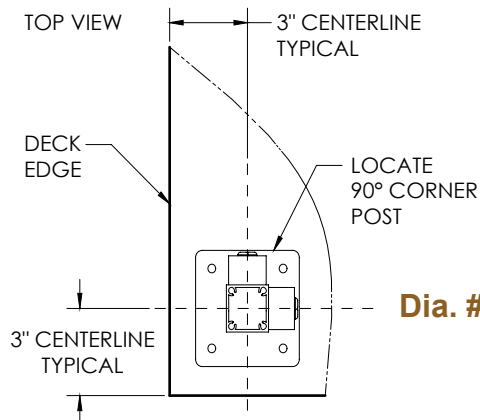

Dia. #7

6 Install 45° Corner Posts

(Post to be installed at 22.5° to accommodate a 45° angle.)

Position post on same 3" centerline (typical) and temporarily fasten to deck surface. Use one 22.5° Panel Attach Kit (purchased separately) to install 45 degree corner posts. (Dia. #8)

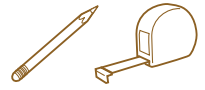
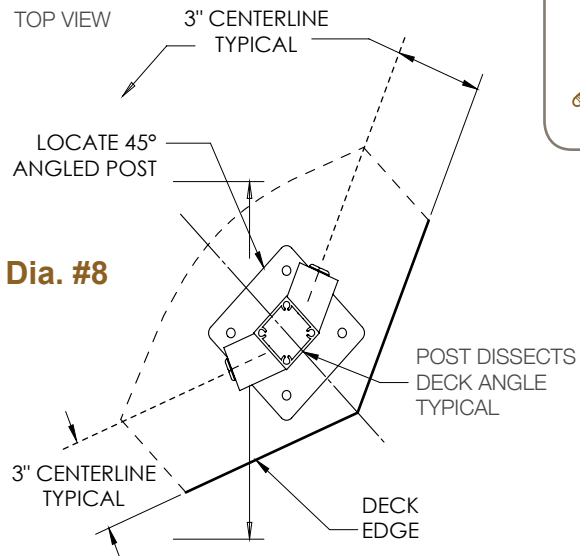

7 Determine Center Post Locations

Loosely lay center post over deck edge and adjust as required to determine final center post mounting locations. (Dia. #9 & #10)

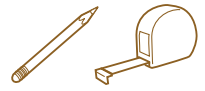
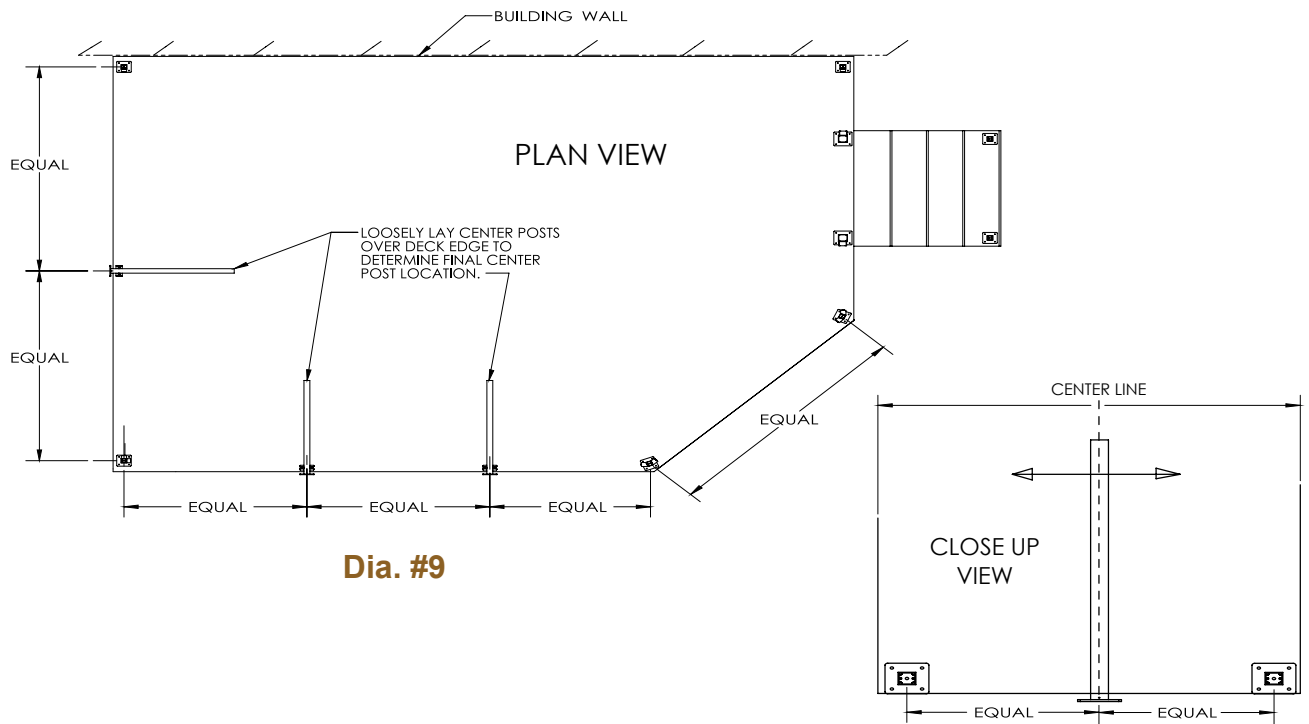

8 Secure 2" Posts to Deck (center only)

- For continuous top rail systems, install 2" posts centered between 3" end and corner posts.

NOTE: 2" Posts must be installed with center screw chases in-line with panel (Dia. #11).

- Follow instructions in step 2 (Dia. #3A to Dia. #4).



Important Note:

3" posts are required at all transitions. 2" posts may not be used to start/end a run or to form a corner.

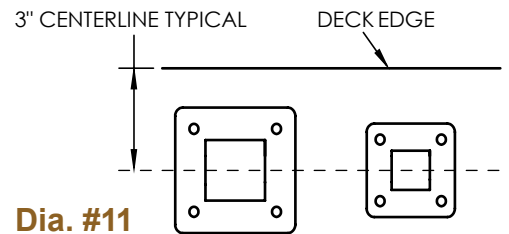
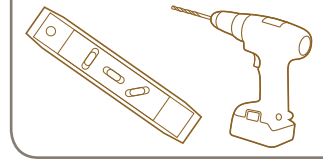

9 Install Crossover Brackets on 2" Posts

- With 6" #2 square drive bit, fasten straight crossover bracket (included) into post with (2) - #8x1.5" Self-Drilling Screws. (Dia. #12A & #12B)
- NOTE: Self-Drilling Screws must be installed in screw chases in-line with panels.**
- With 6" #2 square drive bit, fasten H-channel to straight and stair crossover brackets with (4) - #8x3/4" Self-Drilling Screws. (Dia. #12C & #12D) Repeat for lower clips.
- Install base plate vinyl cover only after railing assembly is completed. (Dia. #4)

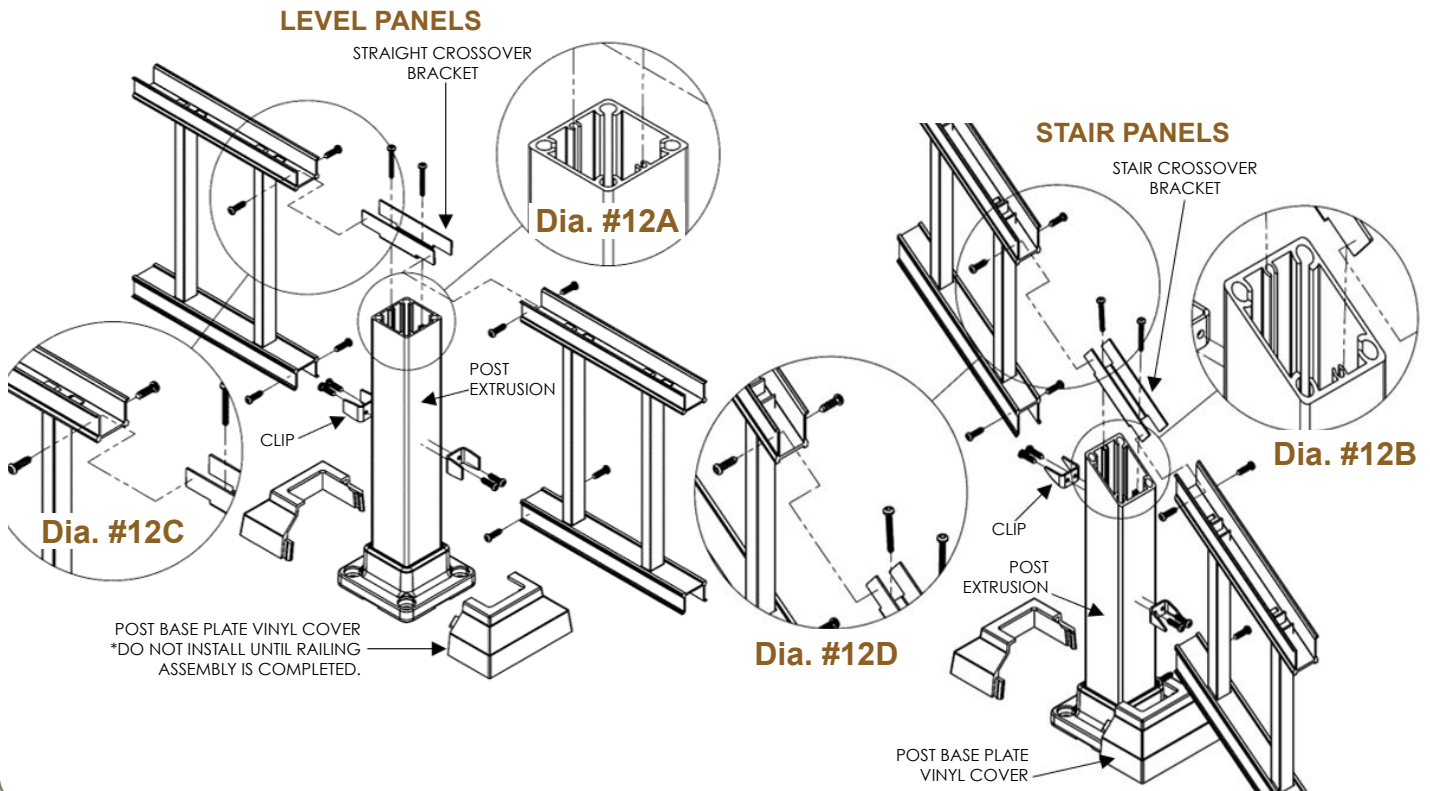
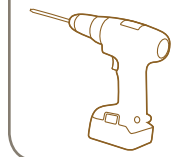

1 Cut Level Panels and H-channels

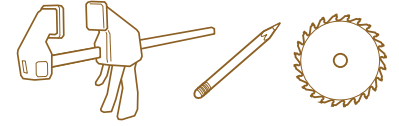

Clamp or hold panel against post, adjust for equal end spacing. (Dia. #1)

- Determine the desired center of the rail; either a baluster hole or between two baluster holes. (Dia. #2)
- Measuring from the determined center, cut both ends of the rails.
- Mark the top and bottom rails and H-channel.
- Cut panel and H-channel 1/16" less than opening size.
- Clean cut areas and apply touch-up paint on exposed ends. Touch-up paint sold separately.

Dia. #1

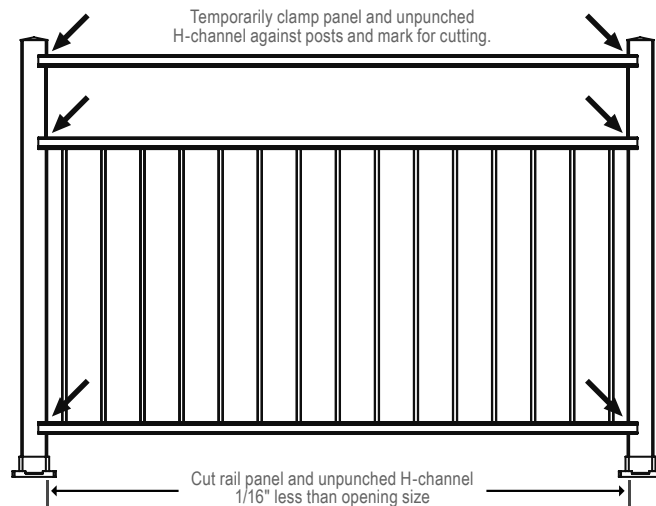

Dia. #2

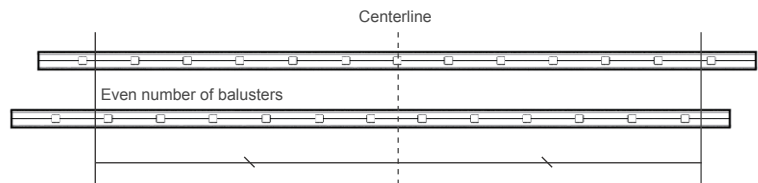

2 Secure Level Panels to Posts

Slide bottom H-channel of pre-cut panel on to lower clip. (Dia. #2)

- Insert clips into top H-channel of panel on each end.
- Using (4) - #8x3/4" self-drilling screws, attach the upper 2-clips to the post.
- Using (8) - #8x3/4" self-drilling screws, secure the upper and lower clips to the panel.
- **Tip:** Use a 6" drill bit for easier installation of top attachment clip to post.

Dia. #2

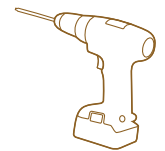
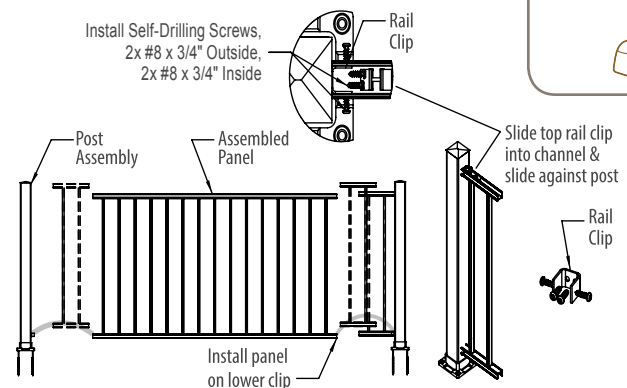

3 Cut and Install Two Bottom Rail Snaps

- Measure between posts at the top and bottom. (Dia. #3)
- For Continuous Top Rail, measure opening from 3" post to 3" post.
- Cut two bottom snap covers 1/16" less than opening(s).
- Clean cut areas and apply touch-up paint on all exposed metal.
- Snap two bottom rail snaps over the rail channels until properly seated. (Dia. #4)

NOTE: Do not install top snaps yet.

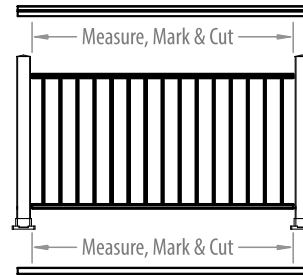

Dia. #3

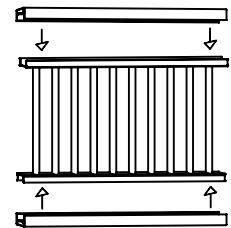

Dia. #4

4 Secure Unpunched H-Channels to Posts

- Measure and mark 3 7/8" above upper bottom snap. (Dia. #5) For Continuous Top Rail System, use crossover brackets on 2" posts. (Page 7, Dia. #11)
- Using (4) - #8x3/4" self-drilling screws, attach the upper 2 clips to the post. (Dia. #6)
- Using (4) - #8x3/4" self-drilling screws, secure the upper clips to the unpunched H-channel. (Dia. #7)

NOTE: Do not install top snaps yet.

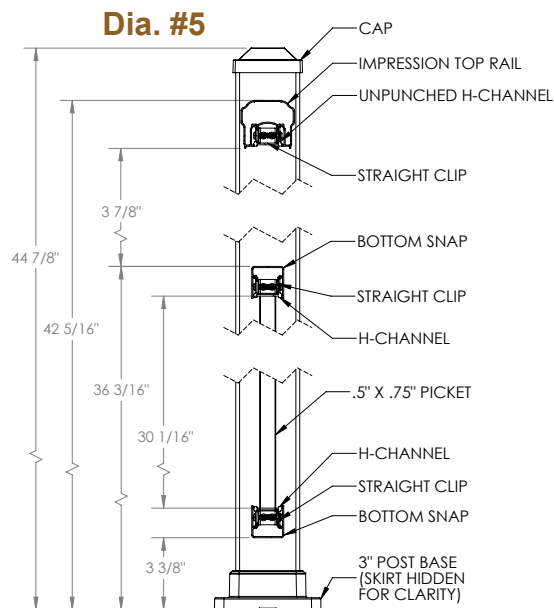

Dia. #5

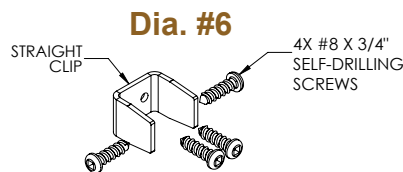
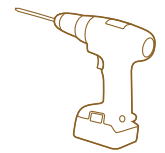

Dia. #6

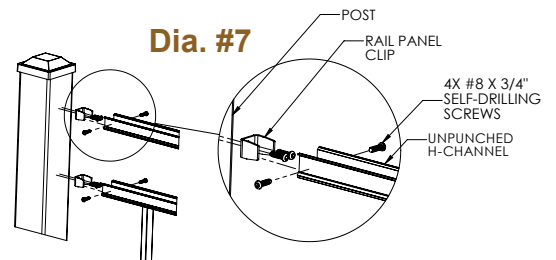

Dia. #7

5 Install Foot Blocks

For openings greater than 4', install foot blocks under center of bottom rail (*Dia. #8*)

- Slide foot block under bottom rail and mark.
- Install two deck screws at location of foot block, install foot block over screws.
- Using (1) - #8x3/4" self drilling screw, secure the foot block to bottom rail, from the outside of the panel so the screw will not be visible from the deck surface. (*Dia. #9*)

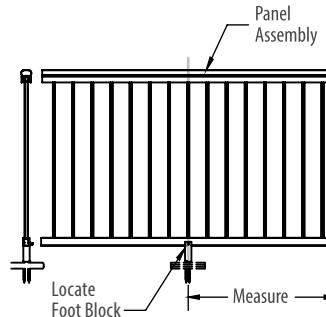

Dia. #8

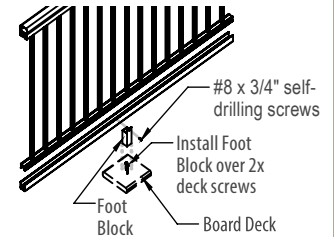
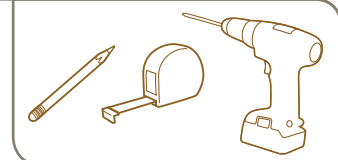

Dia. #9

! Important Note:

The top snap covers should snap firmly onto the aluminum railing channels. **Do not use a hammer.** The top rails will snap by applying pressure from one end to the other. If you're having issues snapping on the covers, check the clips to ensure that they are bottomed out into the aluminum railing channels. **Foot Blocks must be installed BEFORE installing Top Rail Snaps.**

6 Install Top Rail Snaps

- Snap top rail snap over the unpunched H-channel until properly seated. (*Dia. #10*)
TIP: Roll the Top Rail Snap in place to avoid scratching the posts and put weight down to get to the "second" snap.

NOTE: Do not install top snaps yet if lighting wires will be run through top rails.

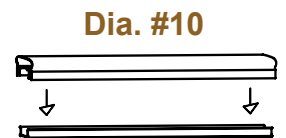

7 Wall Mounts (optional)

Use Wall Mounts if attaching level railing panels to structural surfaces instead of posts.

- One Top Rail Wall Mount and two Bottom Rail Wall Mounts are required to attach one Open Mid-Rail panel to a structural surface. (*Dia. #11*)
- Measure and mark locations on structural surface for placement of three wall mounts. (*Dia. #5 & #12*)
- Attach wall mounts to structural surface.

NOTE: Wall mounting screws are dependent on the type of structural surface. Consult a professional if unsure of proper mounting screws.

- Continue installation of rail panels

Dia. #11

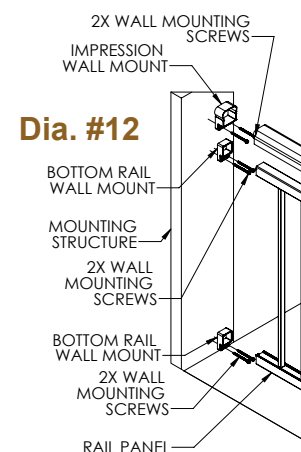
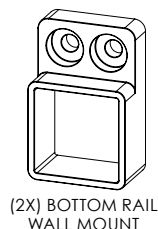
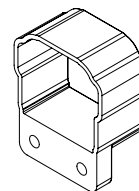

Dia. #12



Important Notes:

- Actual Stair Panel Lengths: 6' Panels = 69.43" and 8' Panels = 91.31". 3" posts are required to reach 6' and 8' lengths.
- Stair railing panels are shipped at a 37 degree angle. Panels are adjustable +/- 3 degrees.
- Maximum post spans on stair railing application is 96" on center. Additional posts are required on any stair application more than 8' in length.
- For all other applications, consult a design professional or an Impression Rail® Express representative for more information.

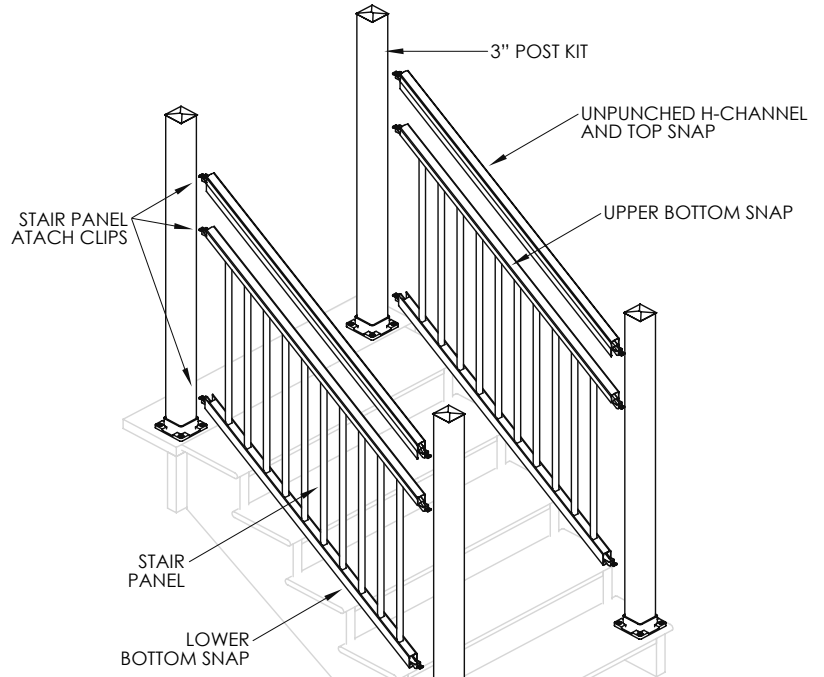

1 Fit Stair Railing Panels

- Position stair railing panel alongside 3" top stair post and temporarily installed 3" bottom post. (Dia. 1A)
- Determine the desired center of the rail: either a baluster hole or between two baluster holes. (Dia. 1C)
- Measuring from the determined center, cut both ends of the rails.
- Position stair panel approximately 1 1/2" above stair nosing. **Tip: lay a 2x4" board flat on nose of stair treads. This will allow enough room for installation of bottom snap.** Clamp stair panel against top and bottom 3" posts. Using a sharp #2 pencil, mark the stair channels at four (4) locations.
- If using a continuous top rail, after panel has been clamped to post, mark cut lines on the H-channel and the 2" post using the bottom of the H-channel to find your angle for post cut. (Dia. 1B)
- Remove clamps and cut stair panel at all four (4) locations. (Dia. 2) Take care to cut stair channels at appropriate stair angle. Use of Miter saw with a sharp non-ferrous blade is recommended.
- Clean cut areas and apply touch-up paint on all exposed ends.

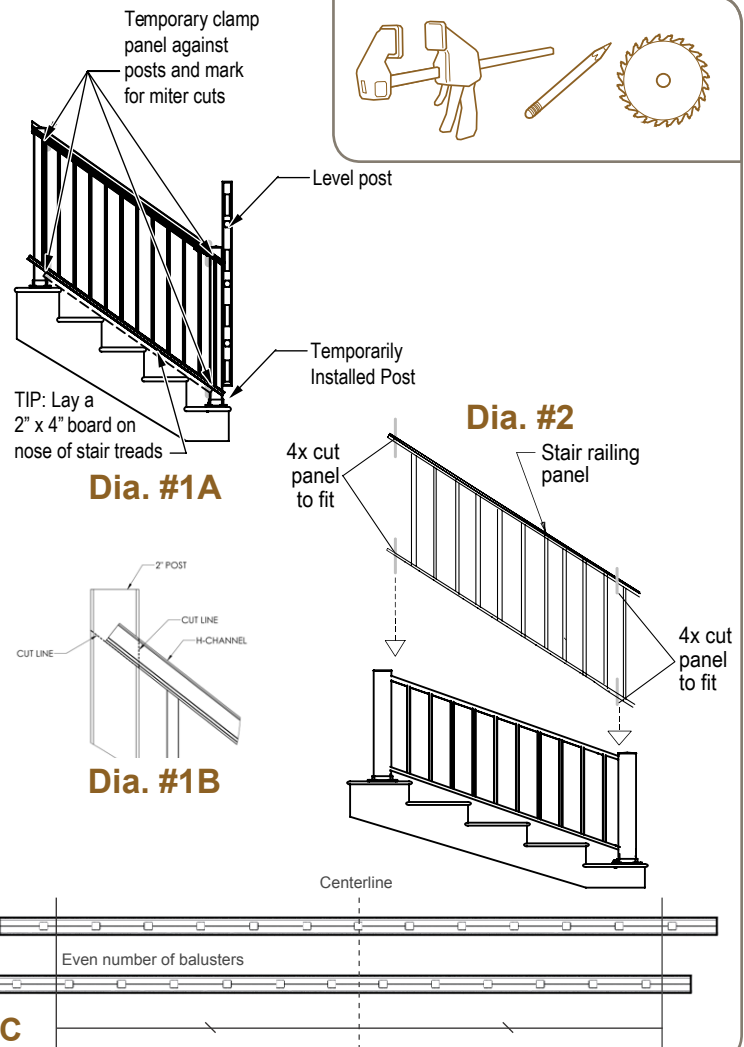

2 Install Stair Clips On Posts

- After stair panel has been cut to proper size and angle, place the panel on the 2x4" (or hold 1 1/2" above stair nosing) board, between the 3" posts. Use a #2 sharp pencil to draw a line across the top of the lower H-channel in two places (Dia. 3).
- Remove panel and bottom post. Attach stair panel attach clips at marked location as per (Dia. 4) and fasten with #8x3/4" self-drilling screws.
- **NOTE: Rail clip jigs are not used for stair panel installation.**

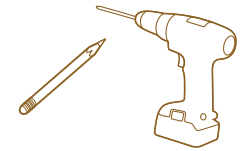
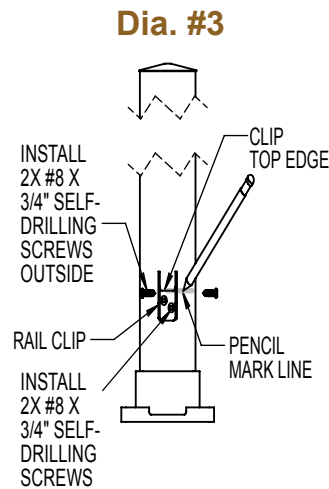

With #2 pencil place mark on post at top of lower stair extrusion

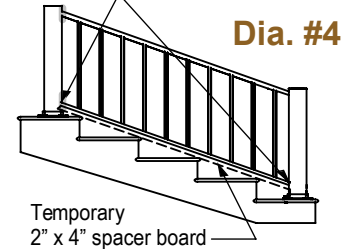

3 Secure Stair Panel To 3" Posts

- Once the stair panel attach clips have been installed, re-attach the lower 3" post to the bottom step or landing. Place the stair panel onto the lower stair panel attach clips (Dia. 5).
- When lower extrusion is fully seated on lower clips, insert stair panel attach clips into upper extrusion. Secure attach clips to post with 2-#8x3/4" self-drilling screws, then secure upper extrusion to stair panel attach clip with 2-#8x3/4" self-drilling screws. Repeat this same procedure for bottom post, upper extrusion (Dia. 6).
- When upper extrusion is secured to attach clips, return to lower extrusion and secure lower extrusion to lower stair clips with 2-#8x3/4" self-drilling Screws at upper post and 2-#8x3/4" Self-Drilling Screws at lower post.

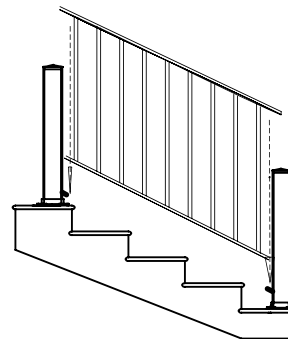

Dia. #5

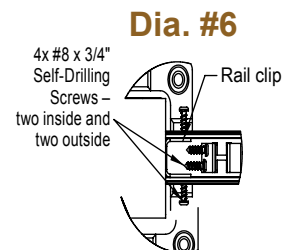
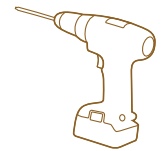

Dia. #6

4 Install Upper and Lower Bottom Snap Covers

- Following the same angle as the secured stair panel, clamp or hold top/bottom rail snaps against 3" posts (Dia. 7). Using a sharp #2 pencil, mark the bottom rail snaps at all four (4) locations.
- Remove clamps and cut bottom rail snaps at all four (4) locations. Take care to cut snaps at appropriate stair angle. Use of Miter saw with a sharp non-ferrous blade is recommended. Cut 1/16" less than opening size.
- Clean cut areas and apply touch-up paint on exposed ends.
- Snap each rail snap over the corresponding rail channel until properly seated (Dia. 8).

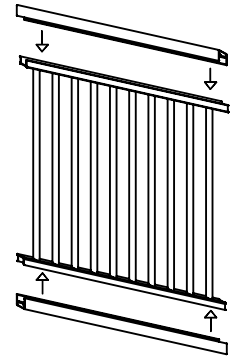
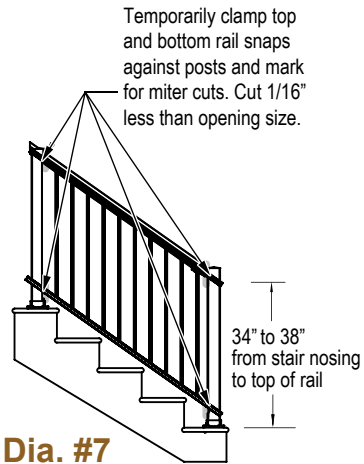
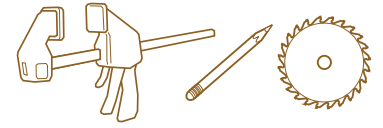

5 Cut Unpunched H-channels

Clamp or hold panel and H-channel against post, adjust for equal end spacing. (Dia. #9)

- Mark cut lines on the top and bottom rails and H-channel.
- Cut panel and H-channel 1/16" less than opening size.
- Clean cut areas and apply touch-up paint on exposed ends.

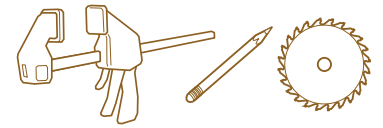
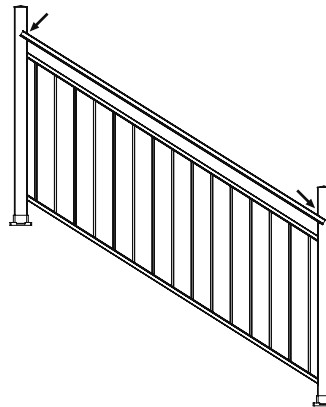

Dia. #9
Temporarily clamp unpunched H-channel against posts and mark for cutting.

6 Secure H-channels to Posts

- Measure and mark 3 7/8" above upper bottom snap. (Dia. #10) For Continuous Top Rail System, use crossover brackets on 2" posts. (Page 7, Dia. #11-12)
- Using (4) - #8x3/4" self-drilling screws, attach the upper 2 clips to the post. (Dia. #11)
- Using (4) - #8x3/4" self-drilling screws, secure the upper clips to the unpunched H-channel. (Dia. #12)
- Snap top rail snap over the unpunched H-channel until properly seated. (Dia. #13)

NOTE: Do not install top snaps yet if lighting wires will be run through top rails.

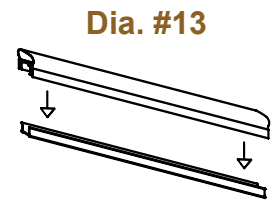
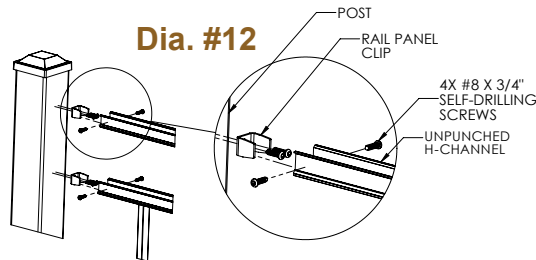
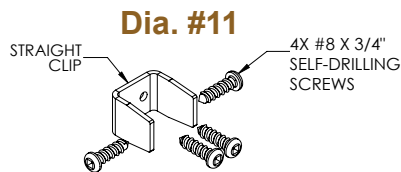
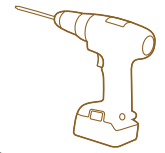
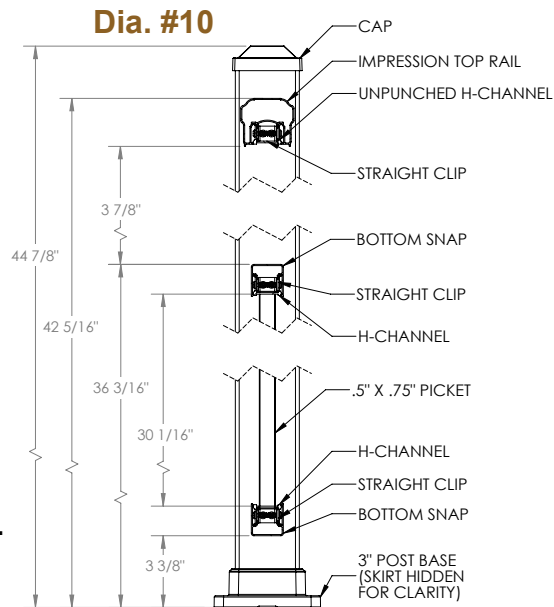

Plan Drawings / Notes



Important Note:

The diagrams and instructions in this brochure are for illustration purposes only and are not meant to replace a licensed professional. Any construction or use of the product must be in accordance with all local zoning and/or building codes. The consumer assumes all risks and liability associated with the construction or use of this product. The consumer or contractor should take all necessary steps to ensure the safety of everyone involved in the project, including, but not limited to, wearing the appropriate safety equipment. Except as contained in the written limited warranty, AZEK does not provide any other warranty, either express or implied, and shall not be liable for any damages, including consequential damages.



AZEK Building Products
1330 W Fulton Market, Suite #350
Chicago, IL 60607

©2019 AZEK Building Products. All Rights Reserved.