



 **TimberTech**®  
**PRO**™

 **TimberTech**®  
**EDGE**™

Installing TimberTech® Decking.....	2
Fastening Methods .....	4
TimberTech® Square Shouldered Planks .....	5
Trimming a TimberTech® Deck .....	6
CONCEALoc® Hidden Fasteners.....	7
Cortex® Hidden Fastening System .....	10
Care and Cleaning .....	12
Warranty.....	13
Notes .....	14

TimberTech Decking should be installed using the same good building principals used to install wood or composite decking and in accordance with the local building codes and the installation guidelines included below. AZEK® Building Products Inc. accepts no liability or responsibility for the improper installation of this product. TimberTech Decking may not be suitable for every application and it is the sole responsibility of the installer to be sure that TimberTech Decking is fit for the intended use. Since all installations are unique, it is also the installer's responsibility to determine specific requirements for each deck application. AZEK Building Products recommends that all applications be reviewed by a licensed architect, engineer or local building official before installation. To get more information visit [TimberTech.com](http://TimberTech.com).

## Access Installation Resources 24/7.

Installation guides and videos are available on our web site at [www.timbertech.com](http://www.timbertech.com)

## Do you need help with your installation?

We have an excellent customer service team that is here to help you with your installation questions. If you need help you can call customer service at 1-800-307-7780 or visit [TimberTech.com](http://TimberTech.com) to view TimberTech installation videos.

## Tools Required

TimberTech planks can be installed with a minimum number of readily available tools. However, many other tools are available that can provide even greater efficiency and ease of installation. All tools should be used per applicable manufacturers' instructions. Some of the basic tool requirements:

- Cordless Driver
- Chalk Line
- Tape Measure
- Jig Saw
- Carpenter Square
- Spacing Tools
- Circular Saw
- Safety Glasses
- Drill Bits

Use the jigsaw to cut around obstructions such as posts. A power miter saw can also be very helpful during installation. For a power miter or compound power miter saw a fine finish alternate top bevel blade is also recommended. When working with TimberTech products be sure to wear proper clothing and safety equipment. Safety glasses should be used during the entire installation process.



## STOP! Read this section before you start!

Always make sure to visit [TimberTech.com](http://TimberTech.com) to ensure you are viewing the most current installation instructions, care and cleaning, technical information and more.

### Walking Surface

TimberTech planks are intended to be installed embossed side up. The unembossed surface is not to be used as a walking surface. This applies to all TimberTech planks.

### Directional Notch

TimberTech's surface on TwinFinish, ReliaBoard, DockSider, TwinFascia and TwinRiser boards are directional in manner. A notch has been added to one side of the planks. When installing planks, this marked edge must be laid to the same side for the entire installation for a consistent appearance. Similarly, TimberTech's TwinFascia board and TwinRiser have one long beveled edge on the front and back. To ensure a consistent appearance from board to board, the beveled edge must be laid to same side. If you rip a piece, be sure to note the location of the bevel. See individual plank installation instructions.

### Static Electricity

The buildup or generation of static electricity is a naturally occurring phenomenon in many plastic based products such as carpeting, upholstery, and clothing, and can occur on alternative decking under certain environmental conditions.

### Cantilevering

All TimberTech PRO, TimberTech EDGE, TwinFinish, Reliaboard, and Docksider can be cantilevered a maximum of 25 mm (1"). All scalloped, PRO Terrain, EDGE Prime, and Reliaboard, can only be cantilevered on the ends.

### Safety

Unlike traditional wood, TimberTech product is splinter-free.

### Color and Grain Patterns

TimberTech Decking is designed to mimic the look of real wood, and like real wood, there will be a slight difference in color and grain pattern from board to board. This is intentional and part of the manufacturing process, giving TimberTech decking the most realistic and wood-like appearance possible. This variation is purely aesthetic and does not or will not affect the performance of the product. TwinFinish, ReliaBoard, and DockSider are designed to naturally weather over time and the surface grain pattern will weather to a more consistent color. Most of the weathering process will be complete within the first year of the deck's life.

### Note

TimberTech is NOT intended for use as columns, support posts, beams, joist stringers or other primary load-bearing members. TimberTech must be supported by a code-compliant substructure. While TimberTech products are great for deck re-planking (removing old deck surface planks and installing TimberTech on code-compliant substructure), TimberTech planks CANNOT be installed on top of existing deck planks.

### Routing

TimberTech Decking SHOULD NOT be routed aside from routing a 51 mm (2") wide groove in the side of solid planks for start/stop of CONCEALoc.

### Notching

Whenever notching a board for a post or any obstruction, the deck board must be handled carefully and be fully supported under the notched area when installed.

## Extreme Heat Warning

Be aware of excessive heat on the surface of TimberTech products from external sources, such as but not limited to, fire or reflection of sunlight from energy-efficient window products. Low-emissivity (Low-E) glass can potentially harm TimberTech products. Low-E glass is designed to prevent passive heat gain within a structure and can cause unusual heat build-up on exterior surfaces. This extreme elevation of surface temperatures, which exceeds that of normal exposure, can possibly cause TimberTech products to melt, sag, warp, discolor, increase expansion/contraction, and accelerate weathering. Current or potential TimberTech customers that have concerns about possible damage by Low-E glass should contact the manufacturer of the product which contains Low-E glass for a solution to reduce or eliminate the effects of reflected sunlight.

## Color and Temperature

Although TimberTech products are cooler to the touch than many other deck board products in similar colors, all decking products will get hot in the sun. Additionally, the darker the decking color, the hotter it will feel.

## Excessive Construction Debris

It is important during construction, that the deck's surface stay clear from excessive build-up of dirt, sand, and dust from tile, concrete, landscape blocks, or any other masonry products. If these materials are not removed immediately, the deck surface will become difficult to clean and can potentially damage the deck's surface finish. TimberTech Decking should not be used as a work surface. If a build-up does occur please refer to the Care and Cleaning section in TimberTech's installation guide or website, [www.TimberTech.com](http://www.TimberTech.com).

## Calculating Material Requirements

To determine how much TimberTech decking material you will need, start by calculating the square footage of your deck surface by multiplying length by width. Once you know this number, divide it by the numbers provided below for 3,66 m (12') planks, 4,88 m (16') planks and 6,10 m (20') planks.

Once you know the square footage number, divide it by 5.5 for 3,66 m (12') planks, 7.3 for 4,88 m (16') planks and 9.1 for 6,10 m (20') planks.

When calculating the amount of decking you will need, it is recommended that you add roughly 10% to the total for a scrap factor.

**Example:** Length x Width = Total Square Footage

Square Footage ÷ by 5.5 (3,66 m (12')), 7.3 (4,88 m (16')) or 9.1 (6,10 m (20')) = Planks Needed (Round the number up)

Planks Needed + 10% (Scrap Factor) = Final Number of Planks Needed (Round the number up)

## ⚠ Working With TimberTech Planks

### Expansion and Contraction

TimberTech deck planks will experience expansion and contraction with changes in temperature. Expansion and contraction are most significant where extreme temperature changes occur. Fastening the deck planks according to the gapping requirements noted in the following table accommodates for this movement.

Changes in length are most significant during the installation process, and should be accounted for if working in extreme temperatures. A good example would be cutting your planks during a hot afternoon, letting them sit outside overnight in the cool air and then installing them the next morning. Chances are, you will notice a certain amount of contraction. The best way to minimize this problem is to fasten your planks as soon after cutting as possible.

### Gapping Requirements For All TimberTech Planks

- Side-to-side plank gapping must be minimum 3 mm (1/8") to maximum 5 mm (3/16").
- Allow 5 mm (3/16") minimum gap where the planking meets any adjoining structure or post.
- Follow these butt joint gapping guidelines for all TimberTech planks:

Butt Joint Gapping Requirements		
32° F and below	33° F to 74° F	75° F and above
5 mm (3/16") gap	3 mm (1/8") gap	0,8 mm (1/32") gap

## Installation Preparation

Follow these guidelines for best deck installation:

- TimberTech Deck Boards are one-sided products. Deck Boards are to be installed with the grain side up for the walking surface. Fascia is to be installed grain side out.
- TimberTech Fascia is one-sided.
- Prior to installation, check to make sure all joists are level, structurally sound, and there are no nails or screws protruding.
- Ensure that all joists are crowned correctly and that all joists are level across the top as TimberTech Deck will conform to the surface contour of the substructure.
- Proper joist spacing is required for proper installation. Joist spacing should never exceed 40,6 cm (16") on center. For a more rigid feel, 30,5 cm (12") may be preferred.
- For best results, installing solid wood blocking between each joist, placed every 1,22 m - 1,83 m (4' - 6') within the structure, can help reduce movement or twisting of the joists. Limiting joist movement can help reduce excessive gapping and also ensure more uniform finished surface of the TimberTech Deck.

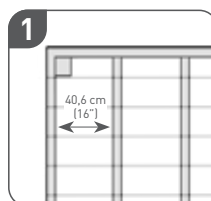

**40,6 cm (16") BASIC INSTALLATION SUBSTRUCTURE**  
40,6 cm (16") on center maximum joists. (30,5 cm (12") on center for commercial applications)

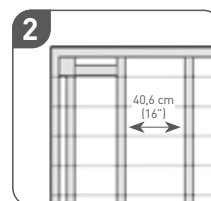

**40,6 cm (16") PICTURE FRAME INSTALLATION SUBSTRUCTURE**  
40,6 cm (16") on center maximum joists plus additional support for picture frame structure (30,5 cm (12") on center for commercial applications)

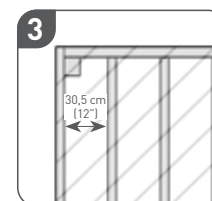

**30,5 cm (12") DIAGONAL INSTALLATION SUBSTRUCTURE**  
30,5 cm (12") on center maximum joists. More severe angles may require closer joist spacing

## TimberTech® Fascia and Riser Boards

Using screws with proper installation of TimberTech Fascia provides the best long-term holding. TimberTech recommends the use of TimberTech TOPLoc Fascia Fasteners for best results. Refer to gapping requirements on page 3 for proper installation.

### For Use with TOPLoc Fascia Fasteners:

Using the TOPLoc Fascia Bit, pre-drill 51 mm (2") from the top and bottom alternating a maximum of 30,5 cm (12"). It is recommended that screws are evenly spaced for the best look.

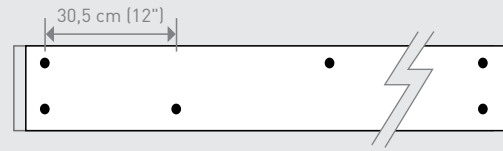

- Set fascia in place being sure to follow proper gapping requirements.
- Drive TOPLoc fascia fastener 90 degrees with the fascia surface so that the screw head is flush with the surface. Do not completely torque down screw; screw should serve as a hanging mechanism to allow for expansion and contraction in the fascia.
- Continue fastening in pattern described being sure to work left to right or right to left. This will ensure flatness in the fascia.
- If preferred, TopLoc Fascia Fasteners may be installed 2 every 30,5 cm (12"), 51 mm (2") from the top and bottom.

## TimberTech® Square Shouldered Planks

TimberTech recommends the use of TimberTech Cortex or TimberTech TOPLoc for square shouldered deck board installations. Pre-drilling is required when within 38 mm (1-1/2") of the ends of the plank and for temperatures below 45 degrees Fahrenheit to avoid splitting and screw shear. Alternate fasteners are stainless steel or high-quality coated composite deck screws.\*

**! Always be sure to check and cut the factory cut ends of all boards to ensure they are square.**

TimberTech PRO, TimberTech EDGE, TwinFinish and Reliaboard: Use Cortex, TOPLoc or a minimum #8 x 64 mm (2-1/2") stainless steel or other high-quality coated composite deck screws.\*

Docksider: Use TOPLoc Stainless Steel or a minimum #8 x 76 mm (3") stainless steel or high-quality coated deck screws.\*

**! Any fastener driven through the edge of a TimberTech PRO, TimberTech EDGE, Reliaboard, TwinFinish, or Docksider board, should not be used to avoid splitting of the board. CAMO® Edge Deck Fastener is an example of this type of fastener. The use of this type of fastener voids any warranty provided with TimberTech Decking.**

### Fastener Mushrooming:

This may occur when a non-composite deck screw is driven into the decking. It can be greatly reduced or eliminated by using a screw designed for composite lumber. When installing TimberTech decking, using TOPLoc reduces chance of mushrooming. If mushrooming occurs, we recommend pre-dimpling the plank by drilling a hole slightly smaller in diameter than the screw head and as deep as the screw head before driving the screw.

\*TimberTech does not recommend any fastener that is not explicitly stated in the TimberTech Decking Installation Guide. Use of any alternative fastener does not void the TimberTech warranty; however, if a decking failure is caused by using one of these alternative fastening methods, any corresponding claims will be denied.

TimberTech EDGE Collection (3- Sided Cap)

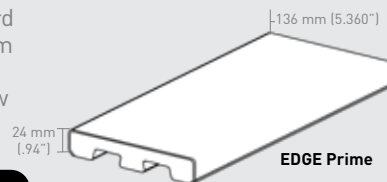

TimberTech PRO Collection (4- Sided Cap)

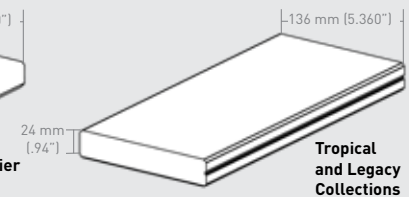
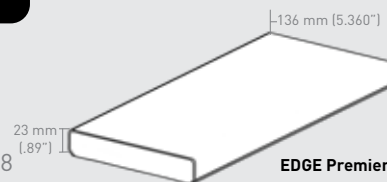
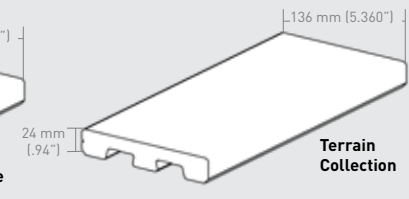

TimberTech Specialty

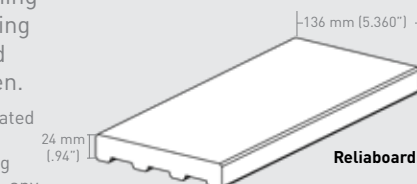
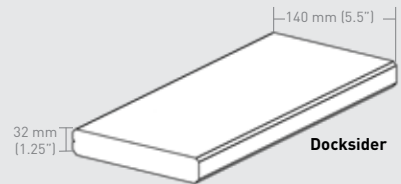
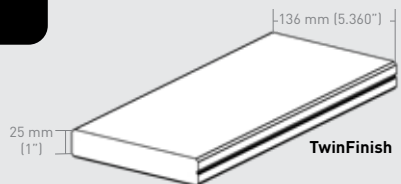

**Fasteners should be installed perpendicular to the deck surface and driven flush; do not overdrive or splitting will occur. Always double joists at butt seams.**

**Do not toe screw deck planks as this will cause splitting.**

## Important Information

To get information on other TimberTech products, visit [timbertech.com](http://timbertech.com) or ask your dealer for these installation guides:

- TimberTech planks are intended to be installed embossed side up. The unembossed surface is not to be used as a walking surface. This applies to all decking surfaces.
- The serrated bottom side of TwinFinish is great for accents like benches and flower boxes.
- In areas with obstructed airflow such as roofs and on-grade applications, a minimum of 38 mm (1-1/2") sleeper system supported by and connected to the substructure over which the deck is built is required.
- To aid water run-off, the deck should slope 13 mm (1/2") for every 2,44 m (8') away from the house.
- To further minimize expansion and contraction, proper ventilation and airflow should be considered.
- For best practices in climates with extreme temperature cycles, limiting the length of the deck plank and avoiding affixing to the rigid length of the joist in applications such as picture framing or parting boards can help avoid movement and screw shear.

- On-grade decks must have additional provisions for drainage beneath the deck structure.
- For best practices, decking should not be installed in applications where ventilation and airflow cannot be achieved.

## Maximum Joist Spacing

TwinFinish			
	90° Angle	30° Angle	45° Angle
100psf	50,8 cm (20")	45,7 cm (18")	40,6 cm (16")
TimberTech PRO, TimberTech EDGE, and ReliaBoard			
100psf	40,6 cm (16")	35,6 cm (14")	30,5 cm (12")
DockSider			
	90° Angle	30° Angle	45° Angle
100psf	61,0 cm (24")	61,0 cm (24")	61,0 cm (24")

Special conditions will require an engineering inspection and/or reduced spans. Always consult local building codes.

## Square Shouldered Plank Installation Instructions

- Always be sure to check and cut the factory cut ends of all boards to ensure they are square.
- Install from the outside edge of the deck and work toward the house.
- Fasten no closer than 19 mm (3/4") from the outside edge of each plank, using two screws per joist including end joints.
- For gapping requirements, see page 3.
- The ends of the planks must fall on a joist. Always double joists at butt seams. Do not toe screw deck planks as this will cause splitting.
- Always install fasteners perpendicular to plank surface and drive flush. Do not overdrive or splitting and mushrooming will occur.
- Pre-drilling is required when within 38 mm (1-1/2") of the ends of the plank and for temperatures below 45 degrees Fahrenheit to avoid end splitting and screw shear.
- TimberTech Cortex requires pre-drilling with a 5 mm (3/16") bit for ALL applications in TimberTech Pro Tropical, Pro Legacy, and EDGE Premier

- If installed without proper 5 mm (3/16") Pre-drill, mushrooming will occur. Cortex or TOPLoc fasteners are recommended for best results.

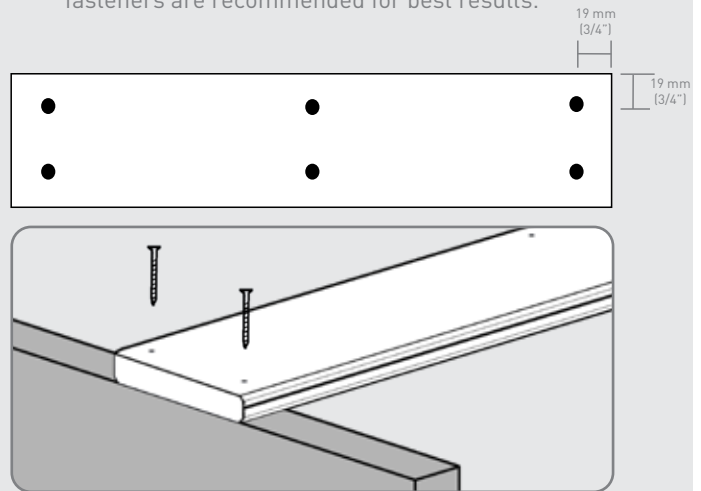

## Directional Notch

**TwinFinish, ReliaBoard, DockSider, TwinFascia and TwinRiser Boards:**  
The surfaces of these products are directional in manner. A notch has been added to one side of the planks. When installing planks, this marked edge must be laid to the same side for the entire installation for a consistent appearance. The TwinFascia board has one long edge beveled on the front and back. To ensure a consistent appearance from board to board when installing the TwinFascia, the beveled edge must be laid to the same side. If you rip a piece of TwinFascia be sure to note the location of the bevel on the ripped piece to ensure consistency.





## Stair Installation

**TimberTech does not recommend installing planks on steps without a riser board.**

- Stairs should be constructed per local code requirements.
- Ensure the stringer step is at least the depth of two full planks plus a 3 mm (1/8") to 5 mm (3/16") gap between planks.
- For gapping requirements, see page 3.
- Ensure there is at least one stringer for support in the middle of the stair span.
- Stair landings and multi-level decks where there is a step down should use the same structural support as required on stairs.

### TimberTech Stair Stringer Spacing Chart

Board	Maximum Spacing
Prime	40,6 cm (16") When used as veneer
Premier	22,9 cm (9")
DockSider	53,3 cm (21")
TwinFinish	30,5 cm (12")
Tropical	25,4 cm (10")
Legacy	25,4 cm (10")
Reliaboard	22,9 cm (9")
Terrain	40,6 cm (16") When used as a veneer

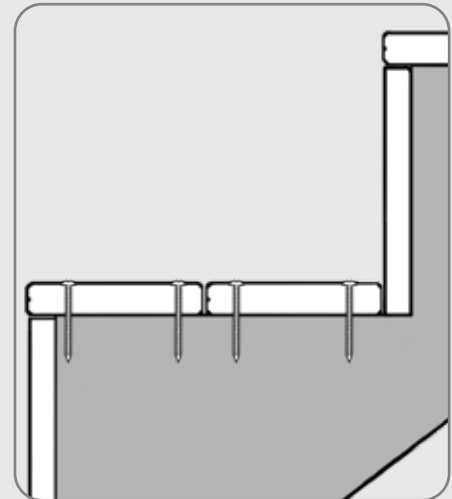

General Stair Installation

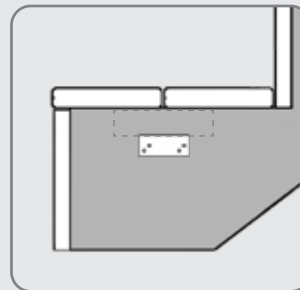

PRO Terrain and EDGE Prime Collections

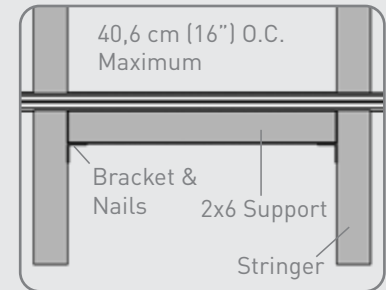

Front View

**! Terrain Collection and Edge Prime must be used as a veneer in a stair tread application. Please see figure to the right.**

### Additional PRO Terrain and EDGE Prime Components

Support	2x6 Support
Bracket	38 mm x 51 mm (1.5"x2.0") Simpson Strong Tie A23Z Galvanized Connecting Angles
Bracket Nails	38 mm (1-1/2") Simpson Strong-Tie N10D5HDG (0.150 in diameter, 0.315 in head diameter) galvanized nails

## Trimming a TimberTech Deck

### TimberTech Fascia Boards:

- For Fascia and Riser Installation, see Fastening Guidelines on page 4.

### TwinFascia®

- Cedar and Grey
- 3,66 m (12') lengths – 14 mm (9/16") thick by 30,5 cm (12") wide.

### Fascia

- All TimberTech PRO and EDGE colors
- 3,66 m (12') lengths – 14 mm (9/16") thick by 30,5 cm (12") wide.

### TimberTech Stair Risers

- Use as a riser for stairs.
- Can also be used as a fascia board for a 2x8 rim joist.
- 3,66 m (12') lengths and 14 mm (9/16") thick x 18,4 cm (7-1/4") wide.

### TwinRiser®

- Cedar and Grey

### Riser

- All TimberTech PRO and EDGE colors

## Important Information

CONCEALoc Hidden Fasteners were designed exclusively to install TimberTech grooved and square shouldered planks.



**Always be sure to check and cut the factory cut ends of all boards to ensure they are square.**

- In areas with obstructed airflow such as roofs and on-grade applications, a minimum of 38 mm (1-1/2"), sleeper system, is required.
- Sleeper system must be supported by and connected to the substructure over which the deck is built.
- To further minimize expansion and contraction, proper ventilation and airflow should be considered.
- On-grade decks must have additional provisions for drainage beneath the deck structure.
- For best practices, decking should not be installed in applications where ventilation and airflow cannot be achieved.
- Do not use CONCEALoc Hidden Fasteners or L-Bracket for stair installation.

## CONCEALoc Accessories

- 9 m<sup>2</sup> (100 ft<sup>2</sup>) coverage box. Includes stainless steel screws.
- Bulk Bucket – 93 m<sup>2</sup> (1,000 ft<sup>2</sup>) coverage. Includes stainless steel screws.
- CONCEALoc Gun Pail – 46 m<sup>2</sup> (500 ft<sup>2</sup>) coverage for use with the fastener installation gun sold separately by TigerClaw. Includes quality coated pneumatic fasteners. Stainless steel fasteners for coastal applications available through TigerClaw.
- L-Bracket – avoid face-screwing by using the L-Bracket on first and last boards or as a butt seam clip to ensure a fastener-free surface.
- CONCEALoc Router Bit – cut a 51 mm (2") wide groove on a solid plank for a perfect CONCEALoc fastener fit – even allows for cutting an installed plank over a joist.
- CONCEALoc screw packs available through [www.timbertechstore.com](http://www.timbertechstore.com).
- If using the CONCEALoc Gun Pail with the TigerClaw Installation Gun please refer to the retail packaging for further installation guidelines.

## CONCEALoc® Hidden Fastener Installation Instructions

### TOOLS NEEDED

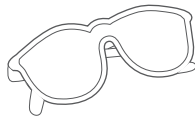

Safety Glasses

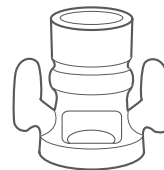

Router with Slot Cutting Blade (Optional)

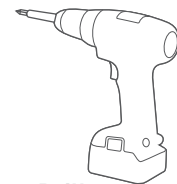

Drill

### 1 INSTALL THE FIRST PLANK

- Pre-drill with 4 mm (5/32") drill bit and fasten outer edge of the first plank at each framing support 1" from the edge using TOPLoc or a #8 x 64 mm (2-1/2") stainless steel or other high-quality coated deck screws. For a complete fastener-free surface, the L-Bracket or Cortex can be used on first and last boards. (Except PRO Terrain, EDGE Prime, and Reliaboard.)
- For further instructions for the L-Bracket or Cortex, please refer to the instructions in the package.

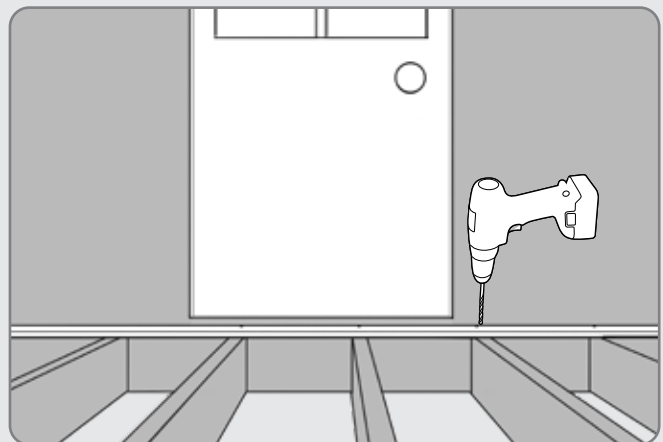

### 2 POSITION CONCEALoc® FASTENERS

- Fully insert the CONCEALoc fastener into grooved edge of plank. Screw hole should be lined up with the center of support joist.

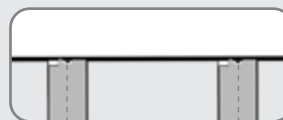

X Incorrect



X Incorrect

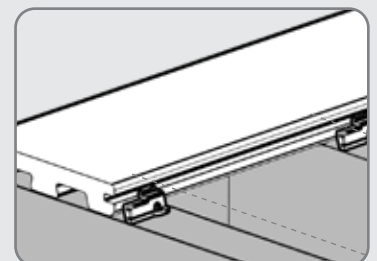

### 3 INSTALL CONCEALoc® FASTENERS

- Install provided screw at 45° angle through the fastener and into the joist while applying pressure on the fastener.
- Install one fastener and screw at each joist.
- Make sure fastener is in full contact with edge of plank and the screw is holding the fastener down tight to the deck board.

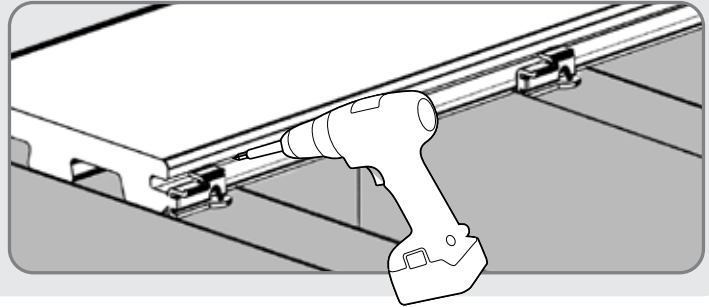

### 4 COMPLETE INSTALLATION

- Place the next plank into position against the fasteners. Slightly raise the outer edge of the plank being installed and slide it onto the fastener until the plank contacts the spacer tab. When properly installed the inserted plank should be in contact with the bent-forward spacer tab at the left end of the clip. To achieve this use a scrap piece of decking at least 61,0 cm (24") in length and use it as a tamping block to drive the plank further onto the clip and the screw will fully engage the plank to the spacer tab if not already in contact. **Do not use a hammer or damage to the edge of the plank will occur.**
- The last plank will need to have the outside edge attached using the method described in Step #1. It may be necessary to rip the last plank to fit.

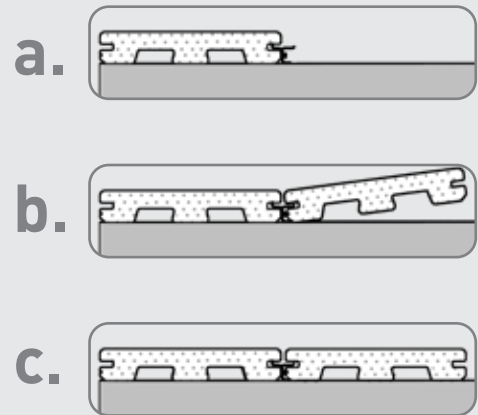

### 5 HOW TO INSTALL AT BUTT JOINTS (UNLESS USING TIMBERTECH® L-BRACKET)

**⚠ Joists at butt joints must be doubled up for proper fastener attachment.**

- Install fasteners as detailed below. Note that the two clips on the right are shifted approximately 6 mm (1/4") to the right of center on the joists. If this is not done the spacer tab may fall within the gap of the butt joint.

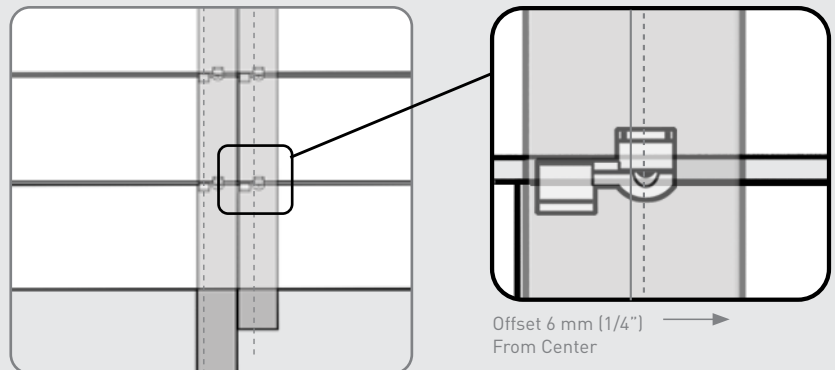



## 6 HOW TO: INSTALL ON DIAGONAL

- When the deck is located in a corner of the house, start with small triangular piece of decking in the corner and work your way out.
- Offset the center 13 mm (1/2") towards the long point of the joist, so screw will not exit the side of the joist when driven.

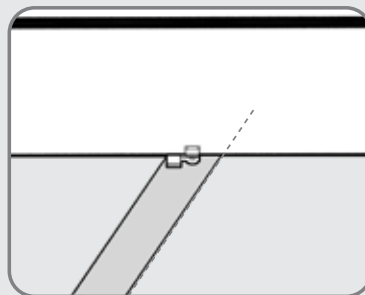

X Incorrect

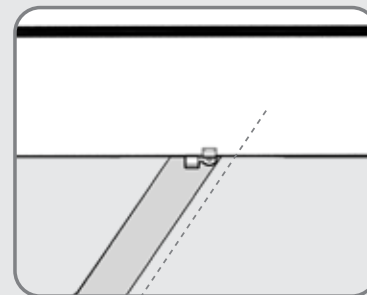

Correct: Shift over 13 mm (1/2")

## 7 HOW TO: REPLACE A PLANK

- Make two parallel cuts down the center of the board to be replaced, then remove the center piece.
- Using a small pry bar, remove the remaining pieces of decking from the tabs.
- Using a reciprocating saw, remove the tabs on the side of the board with the screw heads showing.
- Position new board into place, and carefully drive onto remaining tabs.
- Once the board is set into position, secure the loose edges with L-Bracket, Cortex, stainless steel, or high-quality coated deck screws.

## 8 HOW TO: USE CONCEALoc® FASTENERS WITH SQUARE SHOULDER PLANKS

- Create a 51 mm (2") long groove on the edge of the plank at every joist. Do not groove the full length of square shouldered deck planks.
- Use TimberTech's CONCEALoc Groove Cutting Router Bit or a Freud model #56-112 or Bosch model #85610M 6 mm (1/4") slot cutting bit.
- Flip the plank over and start the groove 10 mm (3/8") off the bottom of the plank.
- Set the depth of the cut from 11 mm (7/16") to 13 mm (1/2") deep.

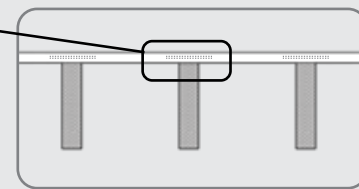
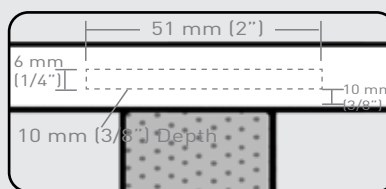

Note: Be sure to ID the side of the plank that has the directional notch; the planks with IDs should be installed to the same side. See Directional Notch on page 5.



**ReliaBoard cannot be grooved. It must ONLY be face-fastened. Grooving ReliaBoard will void the warranty. Do not use CONCEALoc Hidden Fasteners or L-Brackets for stair installations.**

## Cortex® Hidden Fastening System Installation Instructions

### Suggested Drills

Corded or cordless (18V battery) drill with 13 mm (1/2") chuck.

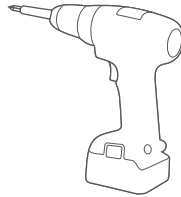

**Impact Drivers are not recommended when using TimberTech Cortex.**



### Important Information

- Pre-drilling with a 5 mm (3/16") drill bit is always required when installing Cortex in TimberTech decking.
- The Cortex Setting Tool must be used to set the Cortex screw to the proper depth.
- The Cortex fastener must be driven perpendicular to the deck surface for proper fit and ideal finished look.
- The cored hole must be free of debris or moisture. Use a smooth hammer head to set the Cortex plug.
- The interaction between the deck board, screw, and plug is essential. Use of non-Cortex Screws or non-Cortex plugs will nullify the warranty.

### End and Edge Distance Minimums

- Pre-drilling is required for installation into TimberTech decking or mushrooming and splitting will occur.
- Pre-drilling should be done with a 5 mm (3/16") drill bit to create the proper pilot hole.
- No fasteners should be installed closer than 19 mm (3/4") from the end or edge of the plank.

### Restricted Cortex Uses

The TimberTech Cortex System is designed for traditional elevated deck surfaces. The following applications require a different fastening method:

- Sleeper systems: Framing rests directly on the ground or roof deck.
- For attaching fascia and riser boards: TimberTech TOPLoc Fascia Fasteners should be used.
- Docks or decks with framing members in constant contact with saltwater.
- Deck materials with a scalloped bottom such as, but not limited to EDGE Prime, PRO Terrain, and Reliaboard.

## 1 PRE-DRILL

- Pre-drill deck board with a 5 mm (3/16") drill bit

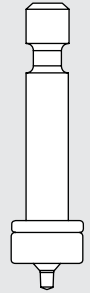
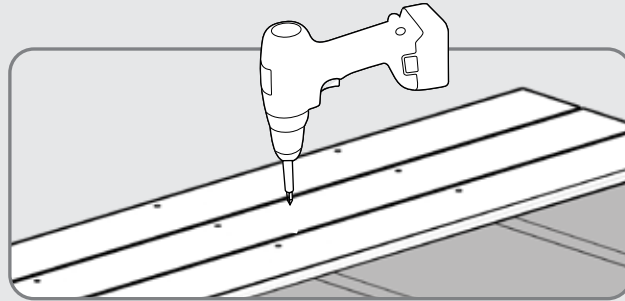

## 2 DRIVE SCREWS INTO JOISTS

- Using Setting Tool provided, drive screw at medium or high speed until it disengages at the proper level below the deck surface.
- Drive at one continuous speed, do not slow down.
- Install two screws into decking at each joist.
- Maximum spacing between each row of screws should be 40,6 cm (16") on center.

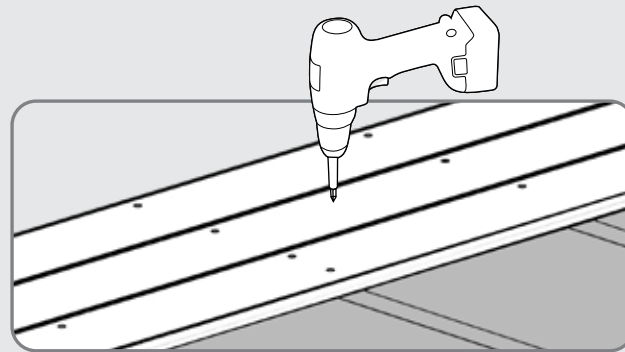

## 3 INSTALL PLUG

- Place plug into cored hole and gently tap flush with deck surface.
- If mushrooming occurs, stop installation and call customer service at 1-800-307-7780.

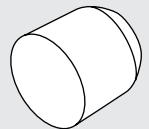
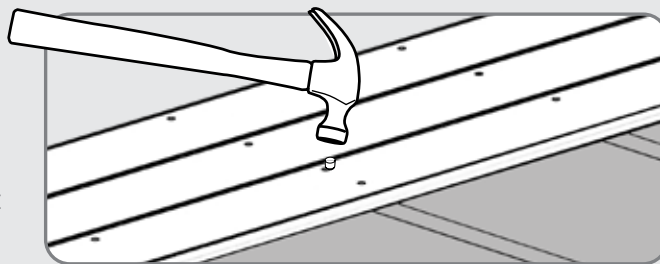

With proper installation and care, TimberTech® products will provide years of outdoor living pleasure.

For most current recommendations or to download a PDF, visit [TimberTech.com/warranty-and-care/care-and-cleaning](https://www.timbertech.com/warranty-and-care/care-and-cleaning)

### Recommended Products for TimberTech PRO™ and TimberTech EDGE™

We know you want to keep your TimberTech Deck clean and looking its best, so here are a few guidelines on the best products and methods to use to keep your TimberTech Deck looking great.

These recommended products can be purchased at many hardware stores including Lowe's and Home Depot as well as online. Always make sure to read the cleaning product manufacturers specific information before using any product on your TimberTech Deck and follow their instructions.

### Storage

Store TimberTech products under cover to maintain a clean surface. If store outdoors, they must be covered with a non-translucent material.

- All products should be stored flat and on a dry surface.
- Stack units with banding and bottom supports aligned.

### Handling

Although all TimberTech planks are made with low-maintenance materials, each plank's unique features require special care and handling ensuring lasting beauty.

To maintain the beauty of TimberTech products, please follow these important guidelines when moving and working with TimberTech:

- Never dump TimberTech materials when unloading.
- When carrying TimberTech planks, carry on edge for better support. When carrying a 6,10 m (20') boards should be carried by 2 persons to more evenly distribute the weight of the board and not concentrate the load at one point.
- Do not slide planks against each other when moving them. When removing them from the unit, lift the planks and set them down.
- Do not slide tools or drag equipment across the top of the planks during construction.
- Keep the surface of the planks free of construction waste to prevent damage to the planks

### Brushes

The correct brush is very important so that it not only cleans the surface, but also does not damage or dull the plank surface. We recommend using either the Quickie® Professional Pool and Deck Scrub or a medium plastic bristle deck brush. DO NOT use a natural fiber deck brush on capped composites as they can dull the surface.

### Cleaner

For general periodic maintenance cleaning, use a dilution of mild liquid soap and water. Dawn Ultra® has shown best results. For more difficult to remove dirt, mud, clay, or surface contamination, use an all purpose cleaner like

Chomp® Pro Gutter Cleaner or Zep® Fast 505.\*Note that composite deck cleaners such as Corte Clean®, Thompson's Water Seal® — Oxy Action, Olympic® Deck Cleaner, or other cleaners specified as composite deck cleaners, in powder or liquid form, should not be used with TimberTech Terrain, Tropical, or Legacy Collections. TimberTech Terrain, Tropical, and Legacy Collection deck planks are a capped composite material, the cap of these products are not compromised of a wood/plastic composite.

### Cleaning Procedures:

In preparation for spot cleaning as well as full surface cleaning, you will need a bucket of water, one of the recommended scrub brushes with an extension handle and one of the recommended cleaners.

Work in small manageable areas. Avoid cleaning in direct sunlight, the UV and heat will dry the surface quickly as you attempt to clean.

Saturate the area with one of the recommended cleaners and allow the cleaner to soak for 30-60 seconds. DO NOT allow the cleanser to dry or evaporate before scrubbing. Rinse area thoroughly with water after scrubbing.

Using the recommended brush and extension handle, scrub using moderate downward pressure, first scrubbing in the direction of the grain and then against the grain getting into the surface texture. DO NOT allow the treated area to dry before rinsing thoroughly as this will allow dirt residue to dry in the surface texture.

Thoroughly rinse the treated area with clean water, then allow the area to completely air dry. Note that any residual cleaner can leave a difficult to remove surface film. Always rinse thoroughly and never allow the cleaner to dry or evaporate on the surface prior to rinse.

### Recommended Products for TwinFinish®, ReliaBoard® and DockSider® Collections

Although TimberTech products are low-maintenance, we recommend periodic cleaning to help maintain the beauty of the product. TwinFinish, ReliaBoard, and DockSider are composite products and cleaning is not the same as for capped composite products. These recommended products can be purchased at many hardware stores including Lowe's and Home Depot as well as online. Always make sure to read the cleaning product manufacturers specific information before using any product on your TimberTech Deck and follow their instructions.

### Power Washing

A power washer can be used when cleaning TimberTech products. The recommended maximum pressure is 1500 psi for TimberTech decks. A fan tip nozzle should be used along with the proper cleaning product. Spray in the direction of the brush/grain pattern to avoid damaging the product. Use caution not to damage the material and always take the proper safety precautions when operation a power washer.

### Cleaner

The cleaners TimberTech recommends for periodic cleaning or use with ReliaBoard, TwinFinish, and DockSider include:

- Wash Safe Spray and Clean Composite Deck Cleaner
- Resist Mist Composite Deck Cleaner
- Corte Clean
- Super Deck Composite Deck Cleaner
- Thompson's Water Seal — Oxy Action

#### **Dirt, Grime, Tannin and Mildew Stains:**

TimberTech wood/plastic composite products are formulated to inhibit mildew growth and minimize staining. Rinse off your TimberTech products periodically with a hose. Even if it appears clean, it is important to prevent build-up of pollen/debris. Mildew stains may occur where moisture, pollens, and/or dirt are present. Mildew needs a food source to grow, which can be grass, pollens, dirt, debris, wood and wood resins.

Maintaining a clean, dry surface is the best method for combating mildew. Ensure that water drains effectively from your deck. For TimberTech TwinFinish, DockSider, and ReliaBoard, be sure that gaps exist between planks to allow for drainage.

### Tannin Staining

Like any other wood-based product, TimberTech's wood-plastic composite products (ReliaBoard, TwinFinish, and DockSider) may experience a naturally occurring process called Extractive Bleeding/Tannins. This process may cause temporary discoloration that will weather away with exposure to flushing rainfall and UV. In most cases the weathering process takes 8-10 weeks but could vary depending on location and specific product application such as a covered porch. Tannins may also be cleaned by utilizing the cleaners referenced for Basic Cleaning Recommendations for ReliaBoard, TwinFinish, and DockSider. These guidelines may not cover every care and maintenance scenario encountered. For additional questions about care and maintenance, call 800-307-7780.

#### **Other Considerations:**

To keep your TimberTech deck looking its best, here are a few additional things to consider. Depending on environmental conditions, TimberTech product colors may appear to weather over time as part of the natural weathering process.

### Heat Buildup

Please be aware that excessive heat build on the surface of TimberTech products from external sources such as, but not limited to, fire or reflection of sunlight can potentially lead to damage. For example, sunlight which may be reflected by low-emissivity (Low-E) glass can potentially lead to damage of exterior building products, including TimberTech Deck, Rail, and accessories, due to elevation of surface temperatures which far exceed that of normal exposure of the same materials to direct sunlight. Possible damage by such reflected, concentrated light may include melting, sagging, warping, distortion, surface discoloration, increased expansion or contraction, and unusual weathering. Although TimberTech Deck products are cooler to the touch than many other deck board products in similar colors, all decking products will get hot in the sun. Additionally, the darker the decking color, the hotter it will feel.

### Static Electricity

The buildup of generation of static electricity is a naturally occurring phenomenon in many plastic based products such as carpeting, upholstery, and clothing, and can occur on alternative decking under certain environmental conditions.

### Snow & Ice Removal

AS with any walking surface, TimberTech decking products may become slippery in winter weather. Take caution when walking on your TimberTech deck in these conditions. Most products containing calcium chloride can be used without damage to the deck/porch surface. These products may leave a white residue which can be cleaned using the cleaning guidelines above. Metal shovels or plastic shovels with a metal leading edge may damage the surface of TimberTech decking and are not recommended for clearing snow from the deck surface.

### Important

Do not allow airborne dust from concrete, landscape blocks, or any masonry product to accumulate on the surface of TimberTech Deck, Rail, and accessories as it may damage the surface of the deck. Do not cut any product on or near TimberTech Decking products. Always remove job site dust, clay, dirt, mud, and other construction dirt and debris to sit on the TimberTech Deck surface. Do not cut metal objects such as railing on the deck surface, the hot debris from the cut may become embedded in the deck surface resulting in staining and damage.

### Warranty

TimberTech products are made exclusively from technologically advanced materials designed to provide years of use and enjoyment. TimberTech PRO, TwinFinish, Reliaboard, and Docksider products are covered by a 30-year limited warranty for residential applications and a 10-year warranty for commercial applications. TimberTech PRO products are covered by a 30 year residential fade and stain warranty. TimberTech EDGE products are covered by a 25-year limited warranty for residential applications and a 10-year warranty for commercial applications. TimberTech EDGE products are covered by a 25-year residential fade and stain warranty. For a complete copy of TimberTech warranties, visit [TimberTech.com](http://TimberTech.com).







# Decking Installation & Maintenance Guide



TimberTech  
894 Prairie Avenue  
Wilmington, OH 45177  
TimberTech.com  
1.800.307.7780